

MODEL SPECIFICATIONS

TL Badge Hanger : UD-854A(H)

Refer to the GENERAL SPECIFICATIONS for common specifications.

SPECIFICATION OF

TL BADGE HANGER

MODEL SPECIFICATIONS

UD-854A

UD-874A

UD-875A

UD-876A

UD-877A

UD-885A

UD-886A

UD-887A

Panasonic Panasonic Industrial U.K.

MATSUSHITA ELECTRIC INDUSTRIAL CO., LTD.
MATSUSHITA INDUSTRIAL EQUIPMENT CO., LTD.
ELECTRONIC EQUIPMENT DEPARTMENT
1-1, 3-CHOME, INAZU-CHO, TOYONAKA
OSAKA, 561 JAPAN

* Specifications subject to change without notice.

MODEL SPECIFICATIONS

TL Badge Hanger : UD-854A(H)

Refer to the GENERAL SPECIFICATIONS for common specifications.

1. Model number : UD-854A UD-854AH
2. Type : Open type for one badge
3. Applicable TL Badge (Examples) : UD-801A, UD-815A
4. Appearance : Fig. 1
5. Body material : ABS resin
6. Front wall thickness : For element 1 open
for element 2 plastics 160 mg/cm²
for element 3 plastics 160 mg/cm²
for element 4 plastics 160 mg/cm²
7. Attaching device : An aluminium clip
(with a nylon strap : UD-854AH only)
8. Color : Clear with slight smokiness.
9. Weight : Less than 7 grams.

MODEL SPECIFICATION
TL Badge Hanger : UD-854A

Refer to the GENERAL SPECIFICATIONS for common

specifications.

1. Model number : UD-854A

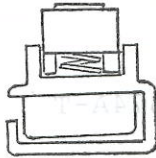

2. Type : (Load type for one badge)

3. Application TL Badge (Examples) : UD-854A, D-854A

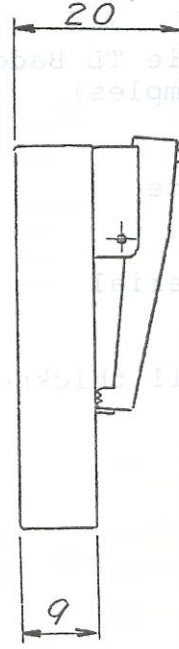
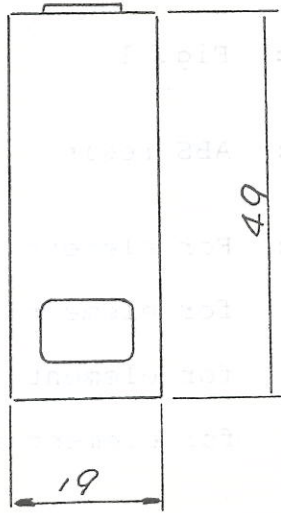

4. Appearance

5. Body assembly

6. Front wall thickness

7. Attaching device

Fig. 1 Structure of hanger: UD-854A.

MODEL SPECIFICATIONS

TL Badge Hanger : UD-874A(H)-T

Refer to the GENERAL SPECIFICATIONS for common specifications.



1. Model number : UD-874A-T UD-874AH-T

2. Type : Closed type for one badge

3. Applicable TL Badge (Examples) : UD-801P, UD-811P

4. Appearance : Fig. 1

5. Body material : ABS resin

6. Front wall thickness : For element 1 plastics 3 mg/cm²
 for element 2 plastics 150 mg/cm²
 for element 3 plastics 150 mg/cm²
 for element 4 plastics 150 mg/cm²

7. Attaching device : An aluminium clip
 (with a nylon strap :
 UD-874AH-T only)

8. Color : Clear with slight smokiness.

9. Weight : Less than 20 grams.

Fig. 1 Structure of hanger: UD-874A

MODEL SPECIFICATION
 The Badge Reader is UD-874A-T

Refer to the GENERAL SPECIFICATION for common specifications.

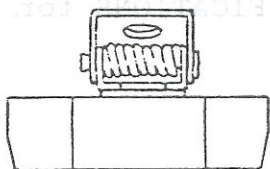

- 1. Model number : UD-874A-T
- 2. Type : Closed type for one badge

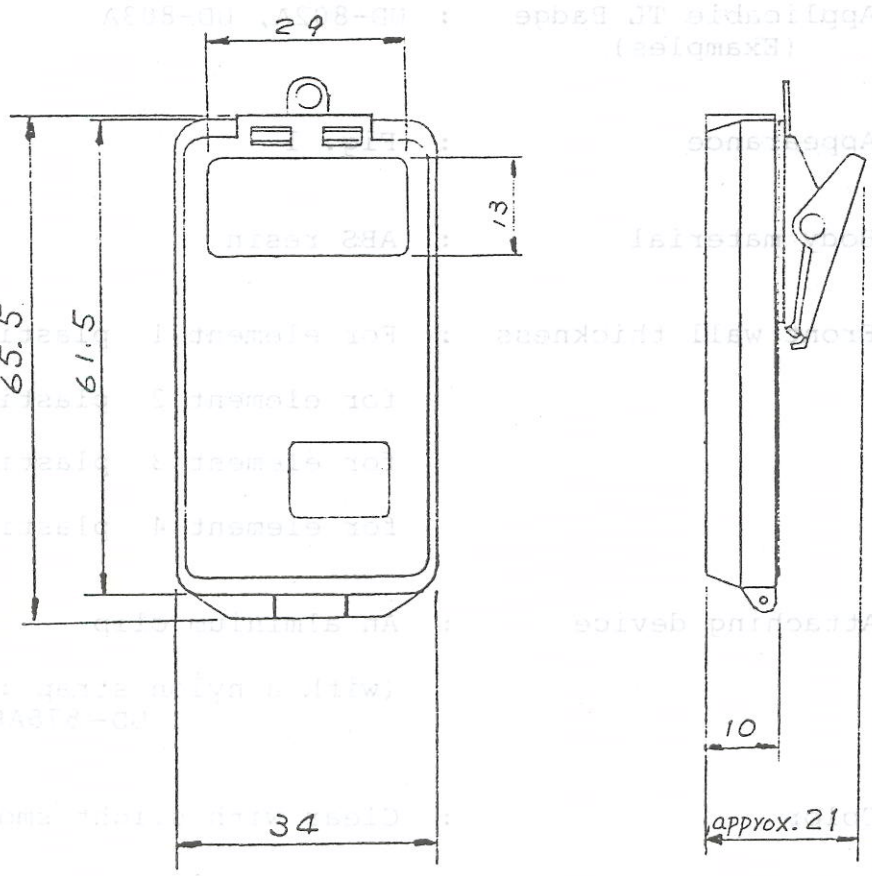

(mm)

Fig.1 Structure of UD-874A-T.

MODEL SPECIFICATIONS

TL Badge Hanger : UD-875A(H)-T

Refer to the GENERAL SPECIFICATIONS for common specifications.

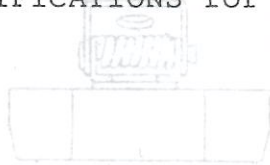

1. Model number : UD-875A-T UD-875AH-T
2. Type : Closed type for one badge
3. Applicable TL Badge (Examples) : UD-802A, UD-803A
4. Appearance : Fig. 1
5. Body material : ABS resin
6. Front wall thickness :

For element 1	plastics	3 mg/cm ²
for element 2	plastics	840 mg/cm ²
for element 3	plastics	840 mg/cm ²
for element 4	plastics	200 mg/cm ²
7. Attaching device : An aluminium clip
(with a nylon strap : UD-875AH-T only)
8. Color : Clear with slight smokiness.
9. Weight : Less than 20 grams.

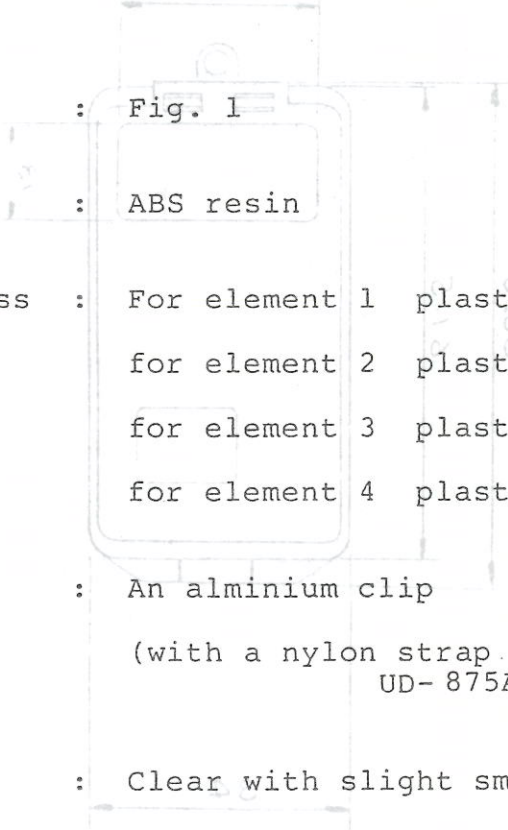
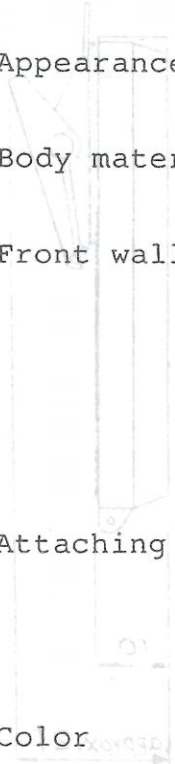
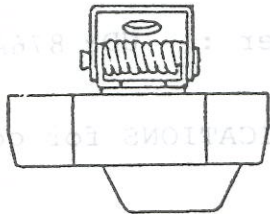

Fig. 1 Structure of UD-875A-T

MODEL SPECIFICATIONS

TL badge hanger : 816A(H)-T

Refer to the GENERAL SPECIFICATIONS for common specifications.



1. Model number : UD-875A-T UD-875A-T

2. Type : Closed type for one badge

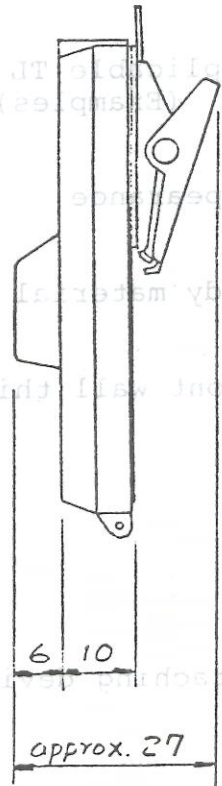
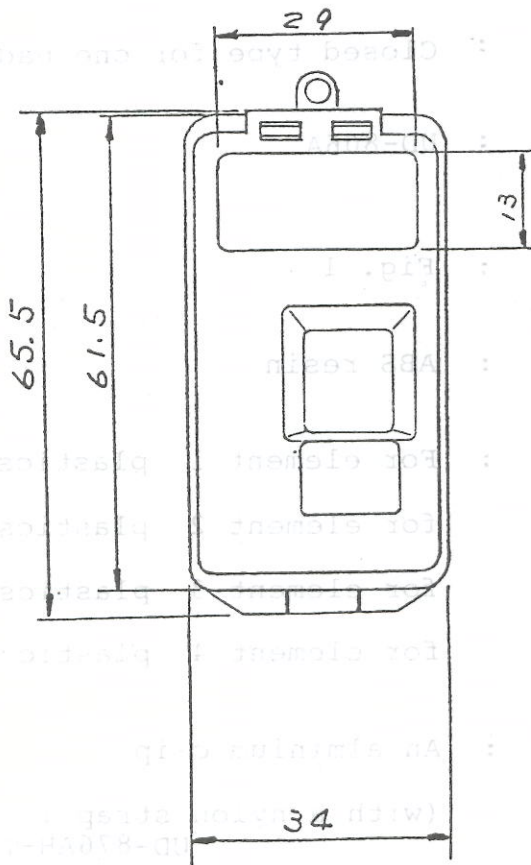

3. Applied TL Badge : (samples)

4. Appearance : Fig. 1

5. Body material : ABS resin

6. Front wall thickness : For element

For element

For element

7. Attaching force : An aiming tip

(with strap UD-875A-T only)

8. Color : Clear with slight smokiness

(mm)

9. Weight : Less than 2g

Weight

Fig.1 Structure of UD-875A-T

MODEL SPECIFICATIONS

TL Badge Hanger : UD-876A(H)-T

Refer to the GENERAL SPECIFICATIONS for common specifications.

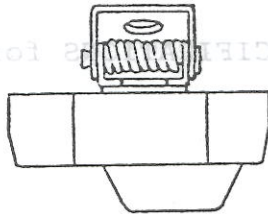

1. Model number : UD-876A-T

2. Type : Closed type for one badge

3. Applicable TL Badge (Examples)

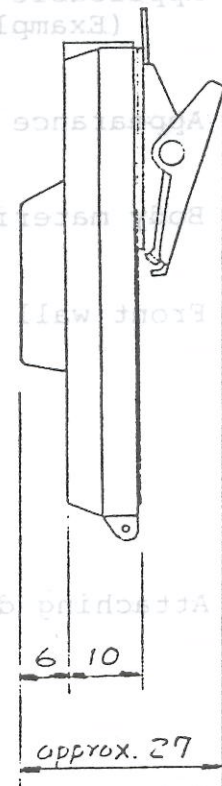
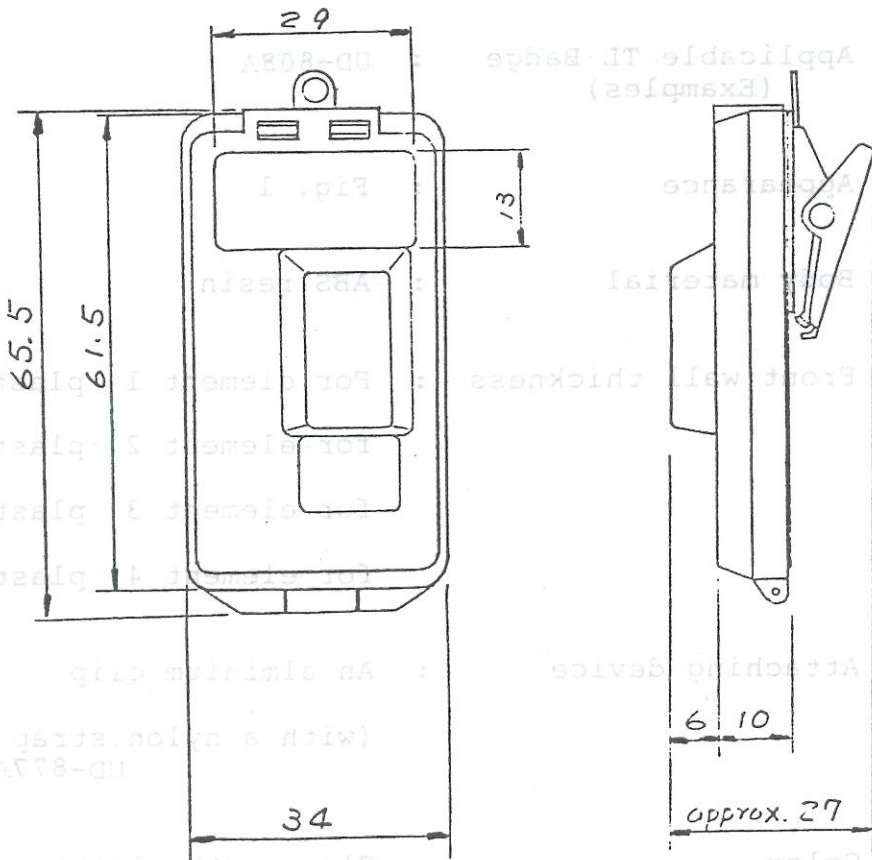

4. Attaching device : An aluminum clip

(with a nylon strap : UD-876A(H)-T)

5. Color : Clear with slight smokiness

6. Weight (m.m.) : Less than 20 grams

Fig. 1 Structure of UD-876A-T

MODEL SPECIFICATIONS

TL Badge Hanger : UD- 877A(H)-T

Refer to the GENERAL SPECIFICATIONS for common specifications.



1. Model number : UD-877A-T UD-877AH-T

2. Type : Closed type for one badge

3. Applicable TL Badge : UD-808A
(Examples)

4. Appearance : Fig. 1

5. Body material : ABS resin

6. Front wall thickness : For element 1 plastics 3 mg/cm²
for element 2 plastics 3 mg/cm²
for element 3 plastics 840 mg/cm²
for element 4 plastics 840 mg/cm²

7. Attaching device : An aluminium clip
(with a nylon strap :
UD-877AH-T only)

8. Color : Clear with slight smokiness.

9. Weight : Less than 20 grams.

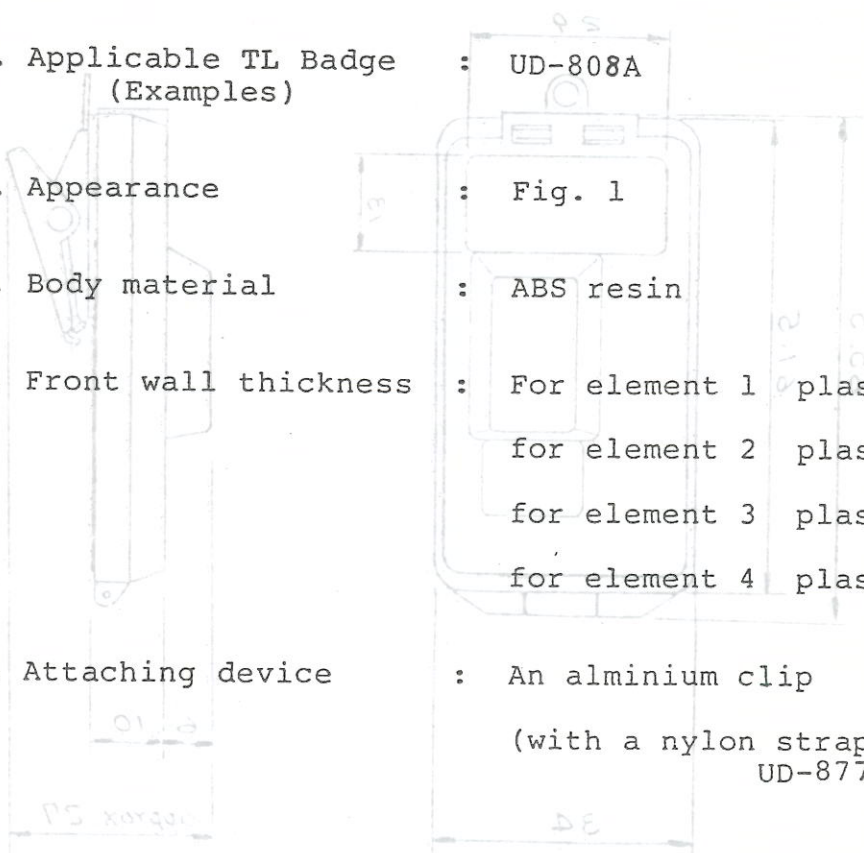
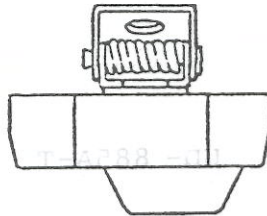

Fig. 1 Structure of UD-877A-T

MODEL SPECIFICATIONS

TL Badge Hanger : UD-882A(H)-T

Refer to the GENERAL SPECIFICATIONS for common specifications.



UD-882A(H)-T

1. Model number

- 2. Type : Closed type for two TL Badges
- 3. Applicable TL Badge : UD-809A and UD-809A or UD-803A (Examples)

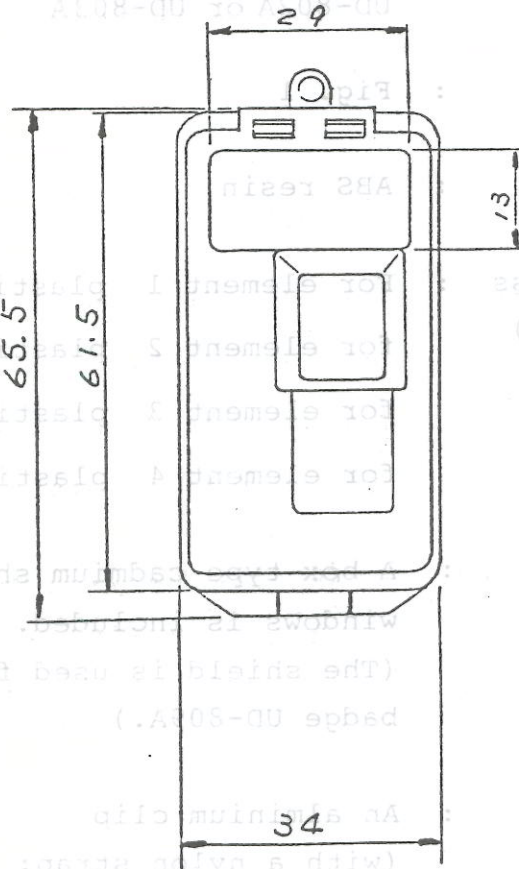

4. Appearance

5. Body material

6. Thickness of element (TL badge)

7. Neutron shield

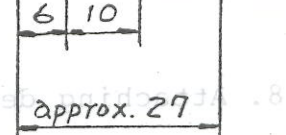

8. Attachment device

Fig. 1 Structure of UD-877A-T

MODEL SPECIFICATIONS

TL Badge Hanger : UD- 885A(H) -T

Refer to the GENERAL SPECIFICATIONS for common specifications.

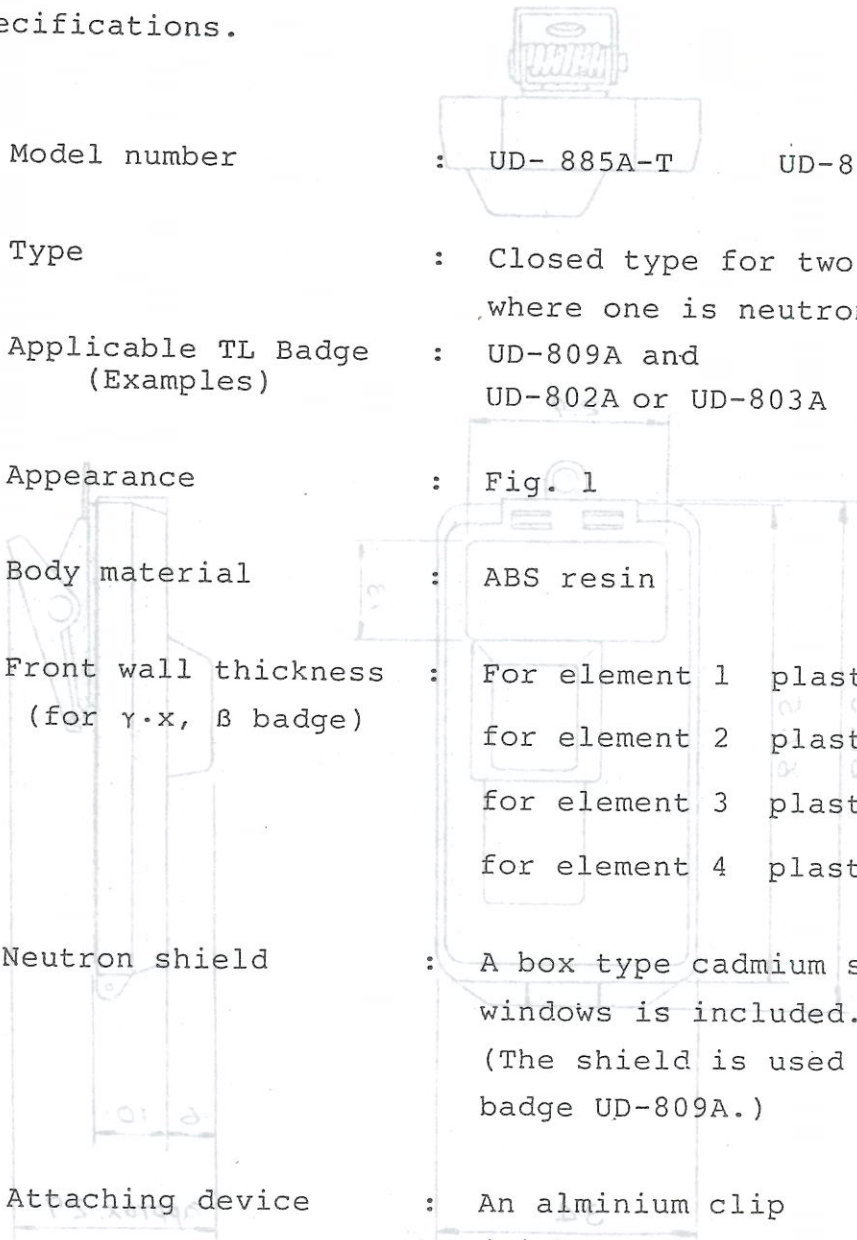
- 
1. Model number : UD- 885A-T UD-885AH-T
 2. Type : Closed type for two TL Badges where one is neutron badge UD-809A
 3. Applicable TL Badge (Examples) : UD-809A and UD-802A or UD-803A
 4. Appearance : Fig. 1
 5. Body material : ABS resin
 6. Front wall thickness (for γ -x, β badge) :

For element 1	plastics	3 mg/cm ²
for element 2	plastics	840 mg/cm ²
for element 3	plastics	840 mg/cm ²
for element 4	plastics	200 mg/cm ²
 7. Neutron shield : A box type cadmium shield with windows is included. Fig. 2. (The shield is used for neutrom badge UD-809A.)
 8. Attaching device : An alminium clip (with a nylon strap: UD- 885AH-T only)
 9. Color : Clear with slight smokiness.
 10. Weight : Less than 45 grams.

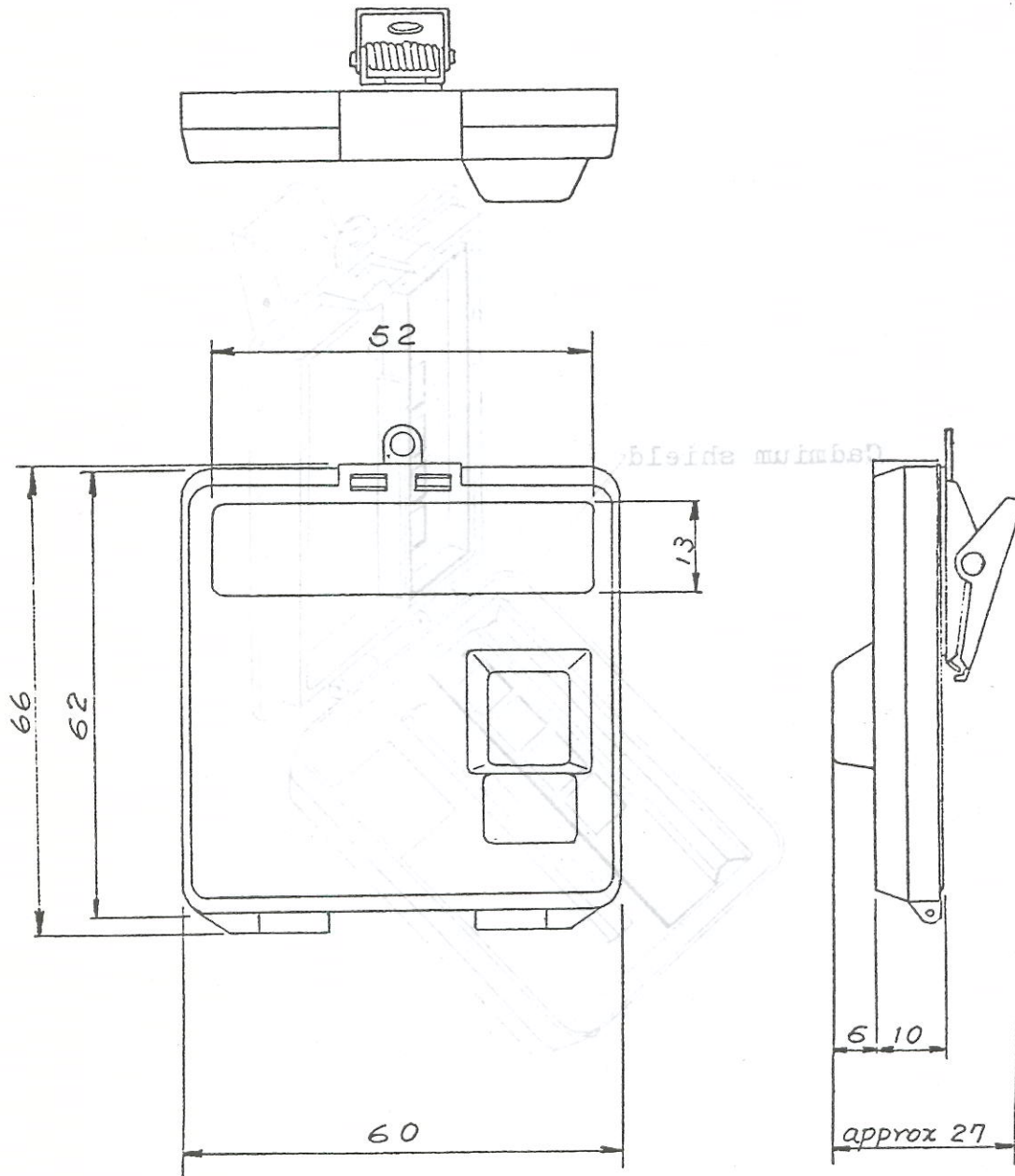

Fig. 1 Structure of UD-885A-T.

(mm)

Fig.1 Structure of UD-885A-T.

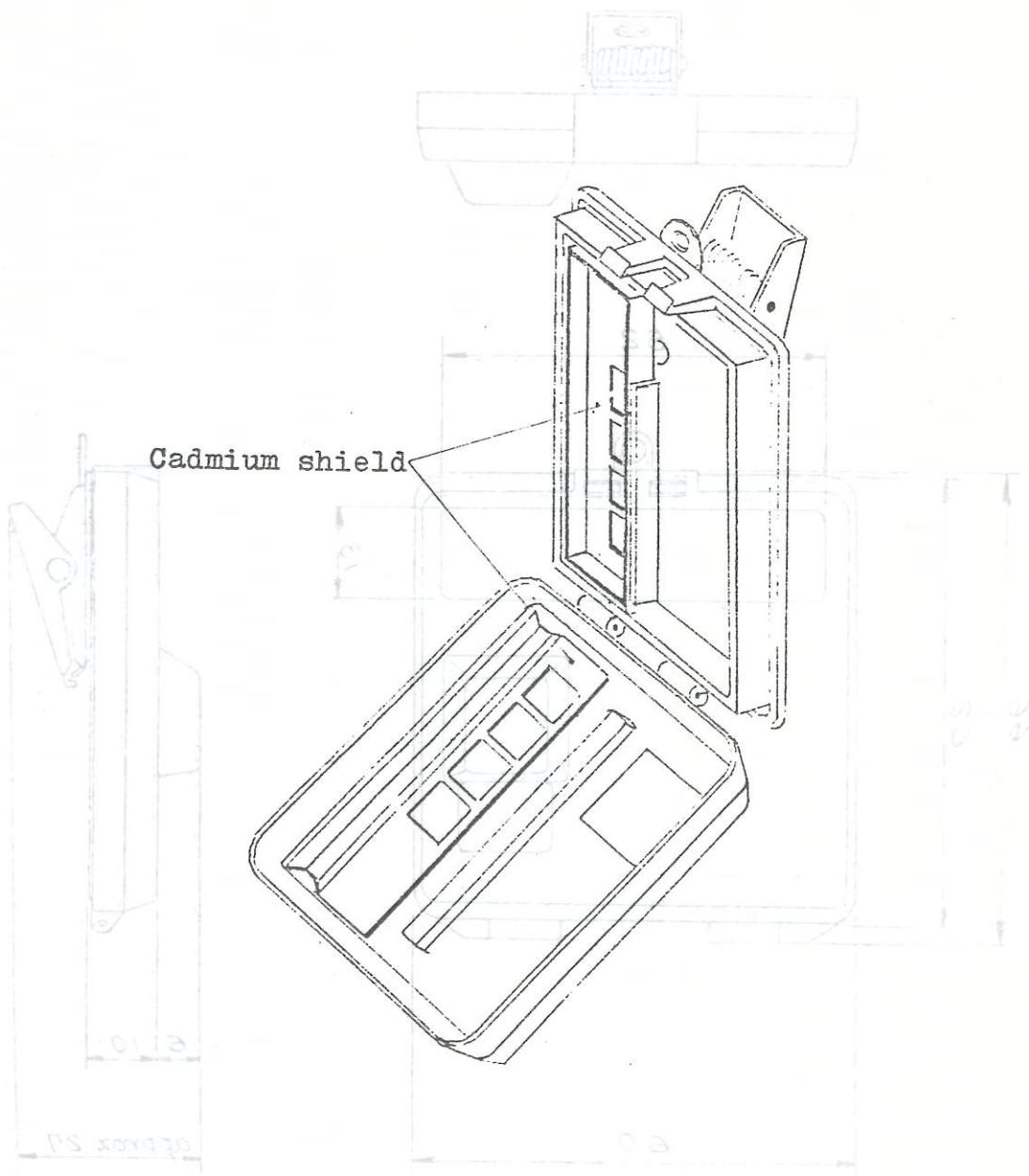

Fig.2 Inside of UD-885A-T

Fig.1 Structure of UD-885A-T

MODEL SPECIFICATIONS

TL Badge Hanger : UD-886A(H)-T

Refer to the GENERAL SPECIFICATIONS for common specifications.

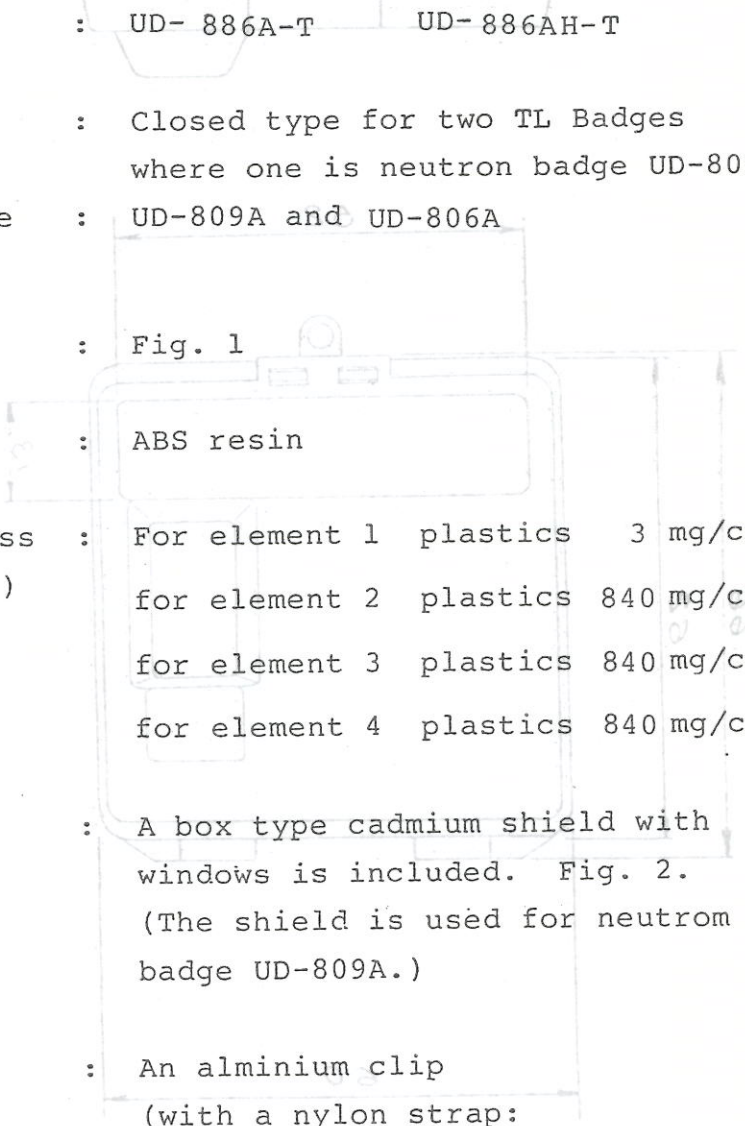
- 
1. Model number : UD-886A-T UD-886AH-T
 2. Type : Closed type for two TL Badges where one is neutron badge UD-809A
 3. Applicable TL Badge (Examples) : UD-809A and UD-806A
 4. Appearance : Fig. 1
 5. Body material : ABS resin
 6. Front wall thickness (for γ .x, β badge) :

For element 1 plastics	3 mg/cm ²
for element 2 plastics	840 mg/cm ²
for element 3 plastics	840 mg/cm ²
for element 4 plastics	840 mg/cm ²
 7. Neutron shield : A box type cadmium shield with windows is included. Fig. 2. (The shield is used for neutrom badge UD-809A.)
 8. Attaching device : An alminium clip (with a nylon strap: UD-886AH-T only)
 9. Color : Clear with slight smokiness.
 10. Weight : Less than 45 grams.

MODEL SPECIFICATIONS

TL Badge Holder : UD-886A(H)-T

Refer to the GENERAL SPECIFICATIONS for common

specifications.

1. Model number

2. Type

3. Applicable TL badge (Examples)

4. Appearance

5. Material

6. Thickness (Examples)

7. Mounting hole

8. Attachment device

(mm)

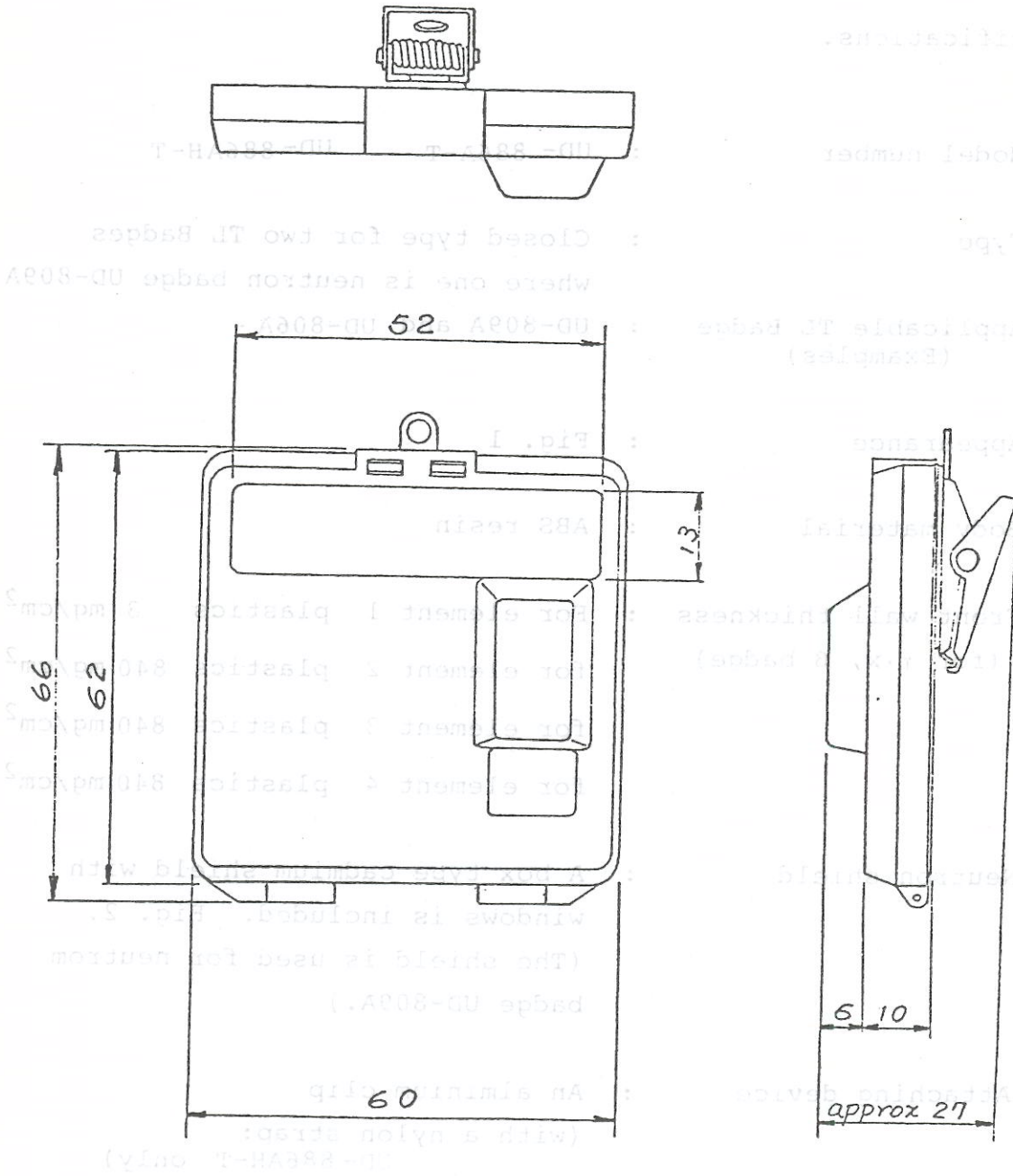

Fig.1 Structure of UD-886A-T

MODEL SPECIFICATIONS

TL Badge Reader : UD-886A-T

Refer to the GENERAL SPECIFICATIONS for common specifications.

- 1. Model number : UD-886A-T
- 2. Type : Closed type for two-TL badge where one is neutron badge UD-809A and UD-808A
- 3. Application (Example) : UD-809A and UD-808A

Cadmium shield

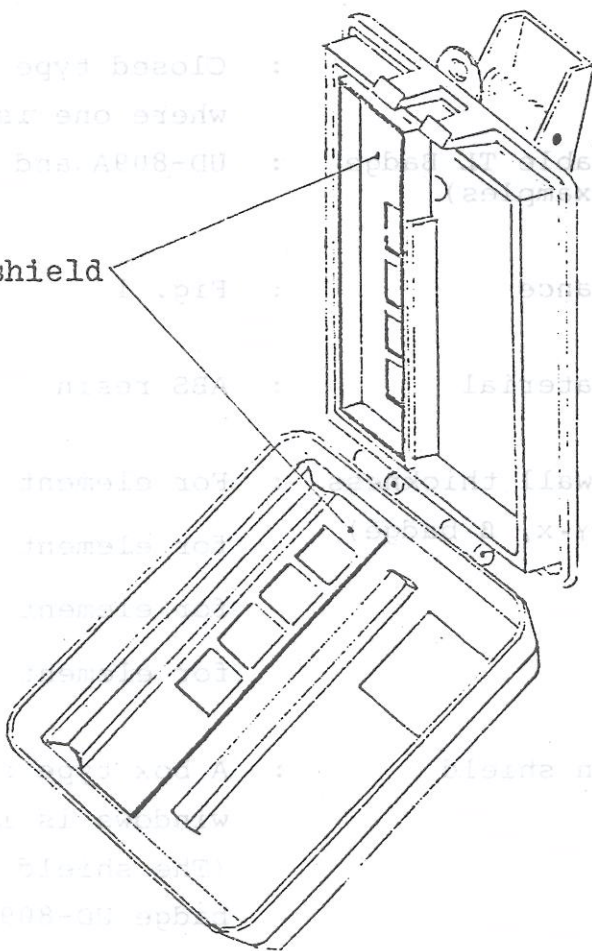

Fig.2 Inside of UD-886A-T

MODEL SPECIFICATIONS

TL Badge Hanger : UD-887A(H)-T

Refer to the GENERAL SPECIFICATIONS for common specifications.

1. Model number : UD-887A-T UD-887AH-T
2. Type : Closed type for two TL Badges
 where one is neutron badge UD-809A
3. Applicable TL Badge : UD-809A and UD-808A
 (Examples)
4. Appearance : Fig. 1
5. Body material : ABS resin
6. Front wall thickness : For element 1 plastics 3 mg/cm²
 (for γ -x, β badge) for element 2 plastics 3 mg/cm²
 for element 3 plastics 840 mg/cm²
 for element 4 plastics 840 mg/cm²
7. Neutron shield : A box type cadmium shield with
 windows is included. Fig. 2.
 (The shield is used for neutrom
 badge UD-809A.)
8. Attaching device : An alminium clip
 (with a nylon strap:
 UD-887AH-T only)
9. Color : Clear with slight smokiness.
10. Weight : Less than 45 grams.

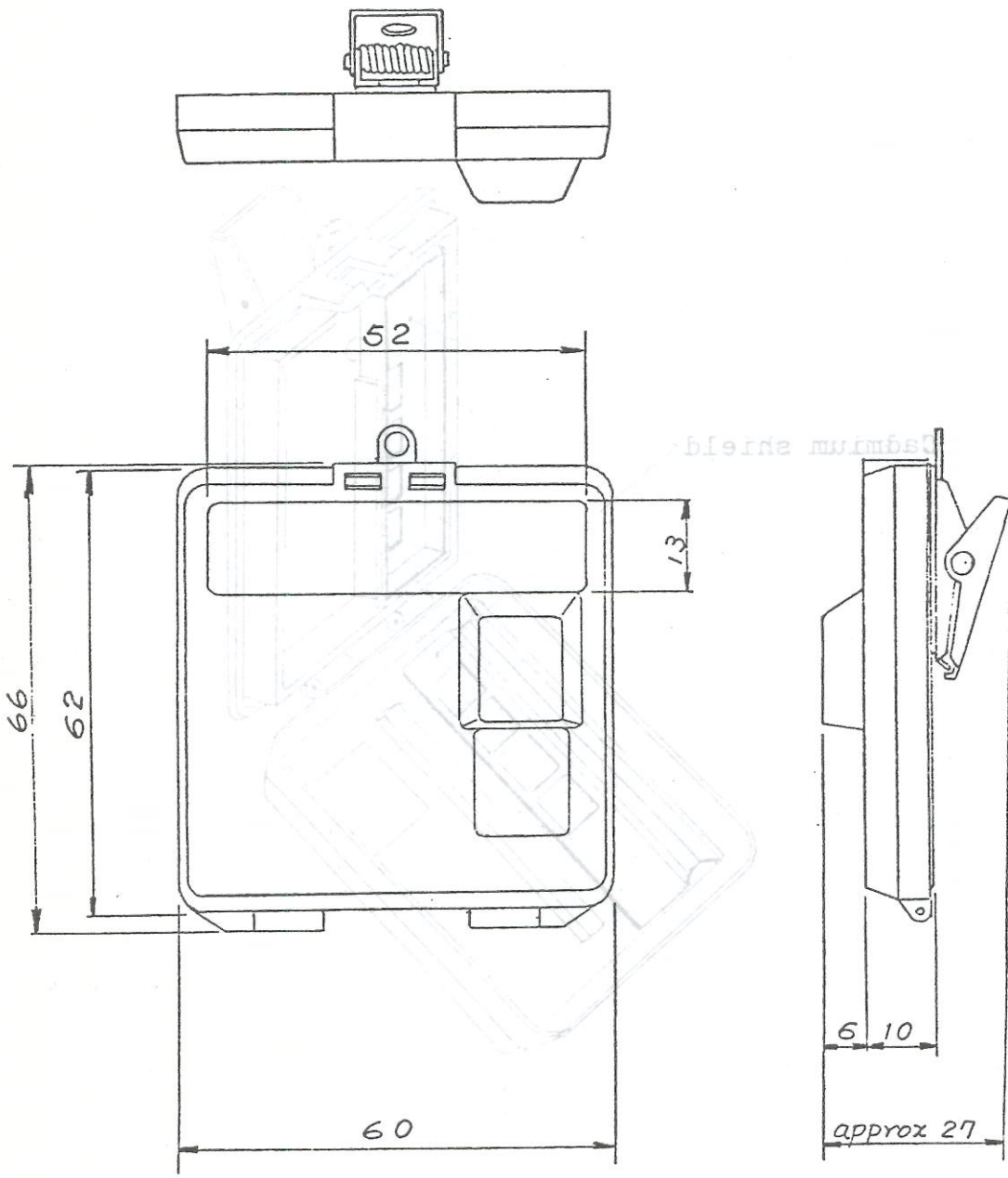

Fig.1 Structure of UD-887A-T.

(m m)

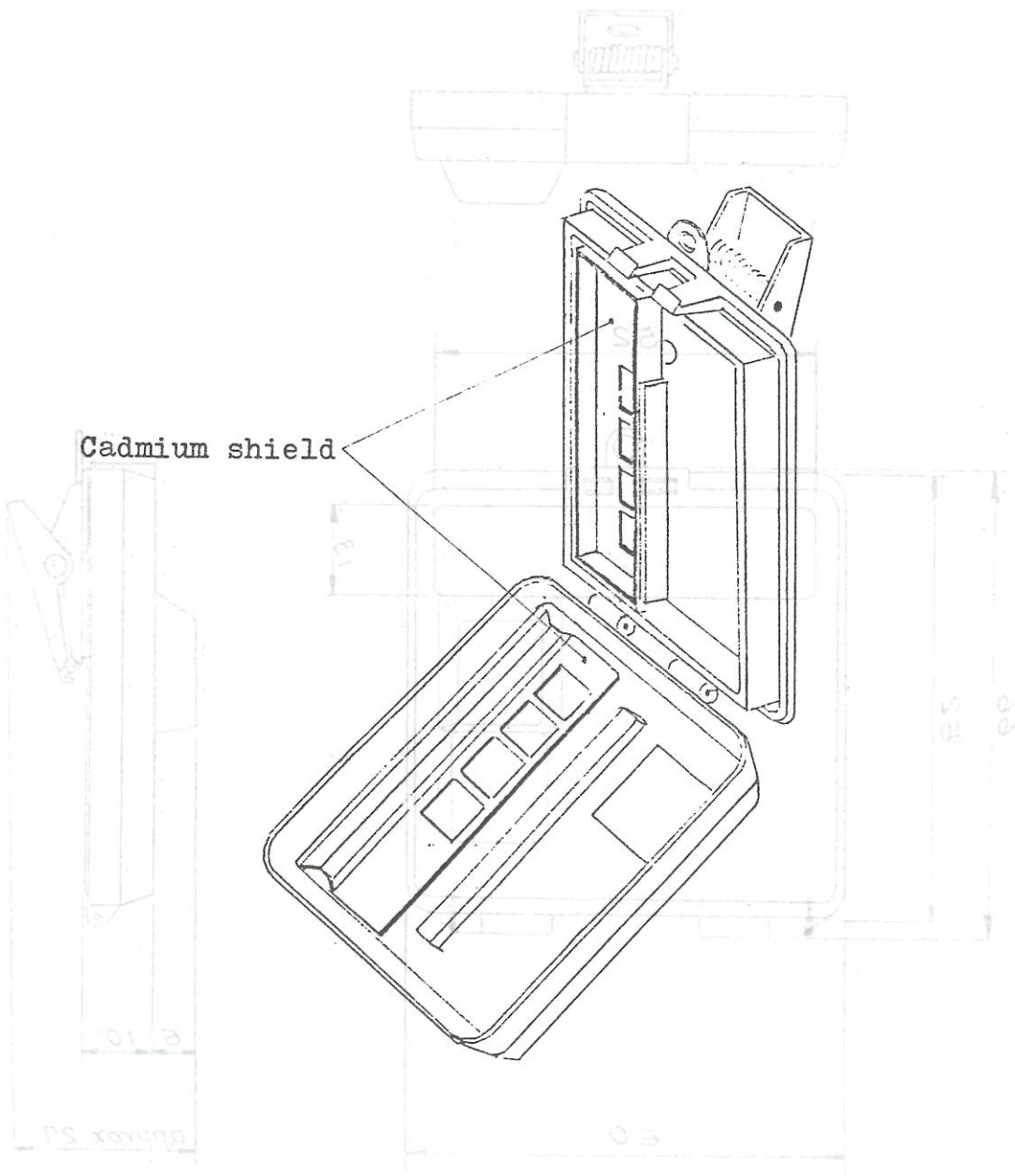

Fig.2 Inside of UD-887A-T.